

# 4" LED Recessed Downlight



## Installation instructions for A4-E26-30-WH

**WARNING:** These products may represent a possible shock or fire hazard if improperly installed or attached in any way. Products should be installed in accordance with these instructions, current electrical codes and/or the current National Electric Code (NEC).

**CAUTION -** To reduce risk of fire, electric shock or injury to persons:

1. Make sure that the electrical power to the fixture is disconnected prior to any installation or retrofit.
2. This light is intended for indoor use only.
3. Use with 4" recessed cans (recessed housings) only. Do not attempt to alter for other sizes or purposes.

**WARNING:** Risk of fire or electric shock. Install these kits only in 4" recessed housings. Confirm this before installation by checking the interior of the housing for a manufacturer's part number and specifications; or measure the diameter of the housing. The recessed housing must have a minimum measured inside diameter (opening) of 3-1/2"; maximum diameter 4-5/8"; minimum clearance of 4". See Figure 1.

Do not make or alter any open holes in a wiring enclosure, nor in any electrical components during kit installation!  
**WARNING:** Risk of fire or electric shock. Kit installation requires knowledge of recessed lighting luminaires electrical systems. If not qualified, do not attempt installation. Contact a qualified electrician.

Do not use these products in luminaires located where elevated ambient temperatures exist.

**WARNING:** Risk of fire or electric shock. The electrical rating of this product is 120V AC. The installer must determine whether power supply is 120V AC at the luminaire before installation.

**WARNING:** To prevent wiring damage or abrasion, do not expose wiring to edges of sheet metal or other sharp objects.

THIS PRODUCT MUST BE INSTALLED IN ACCORDANCE WITH THE APPLICABLE INSTALLATION CODE BY A PERSON FAMILIAR WITH THE CONSTRUCTION AND OPERATION OF THE PRODUCT AND THE HAZARDS INVOLVED.

THE RETROFIT ASSEMBLY IS ACCEPTED AS A COMPONENT OF A FLUORESCENT LUMINAIRE WHERE THE SUITABILITY OF THE COMBINATION SHALL BE DETERMINED BY CSA OR AUTHORITIES HAVING JURISDICTION.

Each fixture includes an attached lead wire with a 120V socket adaptor (for use with either a GU24 or E26 adaptor); an E26 adaptor; an insulating foam ring and a pair of attached torsion clips. See Figure 1.

**FUTURE LAMP REPLACEMENT:** Model A4-E26-30-WH (4" LED Downlight is available from American Lighting, Inc. Contact 800-880-1180 or visit [www.americanlighting.com](http://www.americanlighting.com) to find a local distributor.

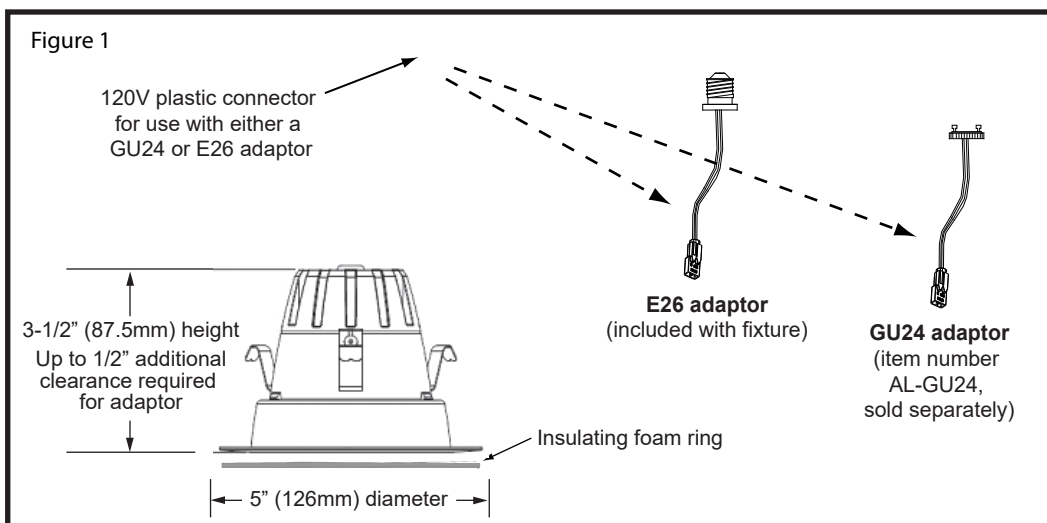

AMERICAN LIGHTING  
[www.americanlighting.com](http://www.americanlighting.com)

©2016 American Lighting, Inc.  
Denver, CO 80231

# 4" LED Recessed Downlight

## Installation instructions for A4-E26-30-WH



**CAUTION:** Always make sure power to the fixture is disconnected before beginning removal of existing lamp and/or trim, or before beginning retrofit installation. Failure to do so can cause electric shock, which can result in injury or death.

### RETROFIT INSTALLATION

1. Confirm the LED trim is compatible with the recessed housing as outlined on reverse.
2. Remove existing lamp from existing recessed housing.
3. Remove existing trim from existing recessed housing.
4. Detach E26 socket adaptor from LED fixture by grasping plastic connectors firmly and pulling apart. Do not grasp wires to pull connectors apart. See Figure 2.
5. Screw E26 socket adaptor into existing E26 socket at the back of the housing; or push and twist GU24 socket adaptor into existing GU24 socket at back of housing. See Figure 3.
6. Insert male connector pins into female connector and press firmly together until fully seated. See Figure 4.
7. Anchor fixture to recessed can, aligning torsion clips with interior wall of can. See Figure 5.

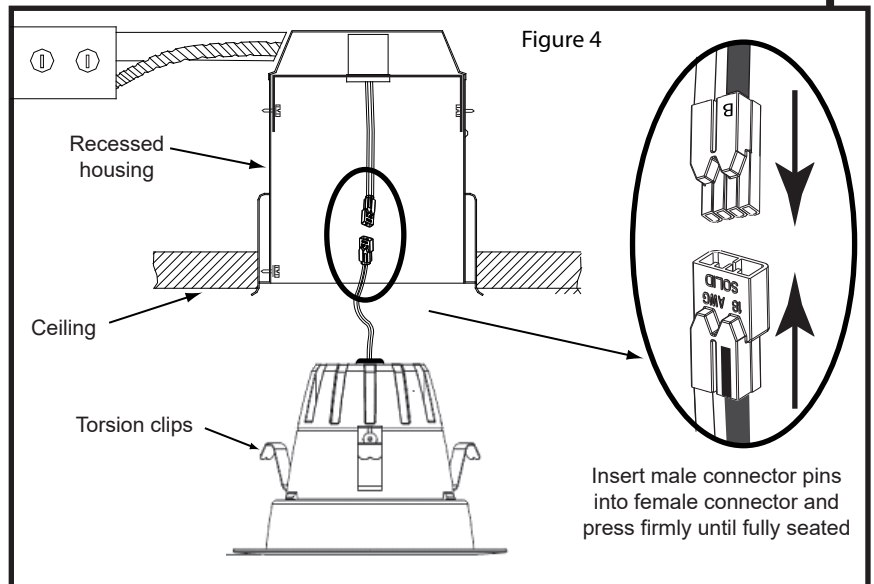
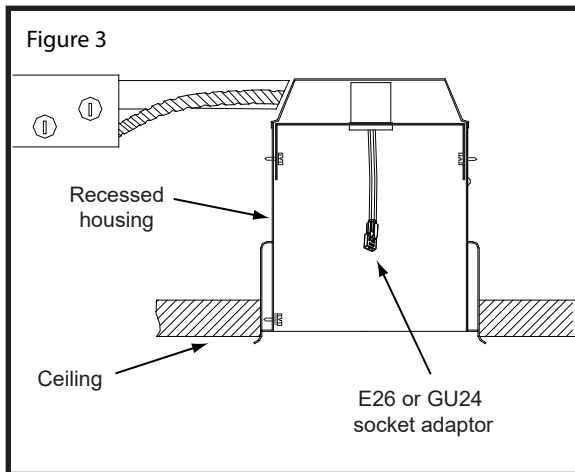
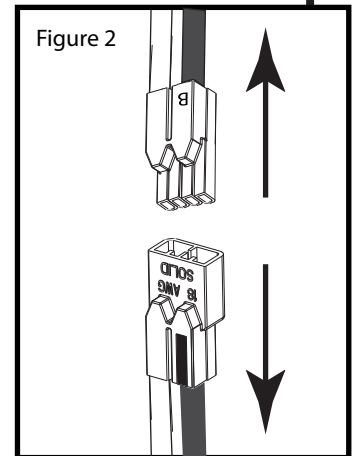

### NEW CONSTRUCTION INSTALLATION

Follow step 1, then steps 4-7 above.

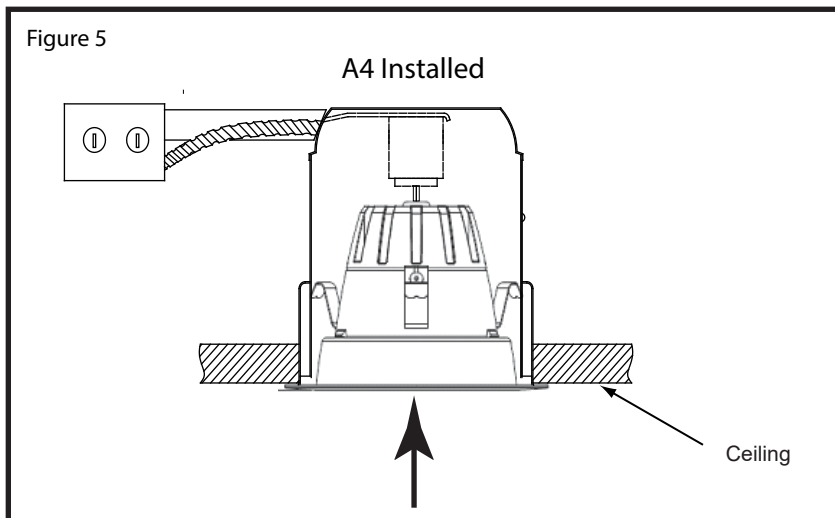

AMERICAN LIGHTING  
[www.americanlighting.com](http://www.americanlighting.com)

©2016 American Lighting, Inc.  
Denver, CO 80231